

## Pumps with peripheral impeller

 Clean water

 Domestic use



### PERFORMANCE RANGE

- Flow rate up to **90 l/min** (5.4 m<sup>3</sup>/h)
- Head up to **100 m**

### APPLICATION LIMITS

- Manometric suction lift up to **8 m**
- Liquid temperature between **-10 °C** and **+60 °C**
- Ambient temperature up to **+40 °C** (**+50 °C** for PK 60)
- Max. working pressure:
  - **6 bar** for PK 60, PK 60-MD, PK 65,
  - **7 bar** for PK 70, PK 80
  - **10 bar** for PK 90, PK 100, PK 200, PK 300
- Continuous service **S1**

### CONSTRUCTION AND SAFETY STANDARDS

EN 60335-1  
IEC 60335-1  
CEI 61-150

EN 60034-1  
IEC 60034-1  
CEI 2-3



### CERTIFICATIONS

Company with management system certified DNV  
ISO 9001: QUALITY

### INSTALLATION AND USE

Suitable for use with clean water that does not contain abrasive particles and with liquids that are not chemically aggressive towards the materials from which the pump is made. Because of their reliability and the fact that they are easy to use and are economical, they are ideal for domestic use and in particular for distributing water in combination with small pressure tanks and for the irrigation of gardens and orchards. Installation needs to be undertaken in well ventilated closed areas or anyway protected from bad weather.

### PATENTS - TRADE MARKS - MODELS

- Motor bracket: patent n. IT1243605
- Shaft: patent n. 0000275945 (PK60, PK65)
- Pump body: patent n. 0000275946 (PK60, PK65)
- Registered EU Design n. 004673192
-  **PKm 60**® Registered Trade Mark n. 009875394

### OPTIONS AVAILABLE ON REQUEST

- Pump body with NPT ANSI B 1.20.1 threaded ports
- Special mechanical seal
- Other voltages
- IP X5 class protection for PK 70-80-90-100-200-300

### GUARANTEE

2 years subject to terms and conditions

### CHARACTERISTIC CURVES AND PERFORMANCE DATA

60 Hz n= 3450 min<sup>-1</sup> HS= 0 m

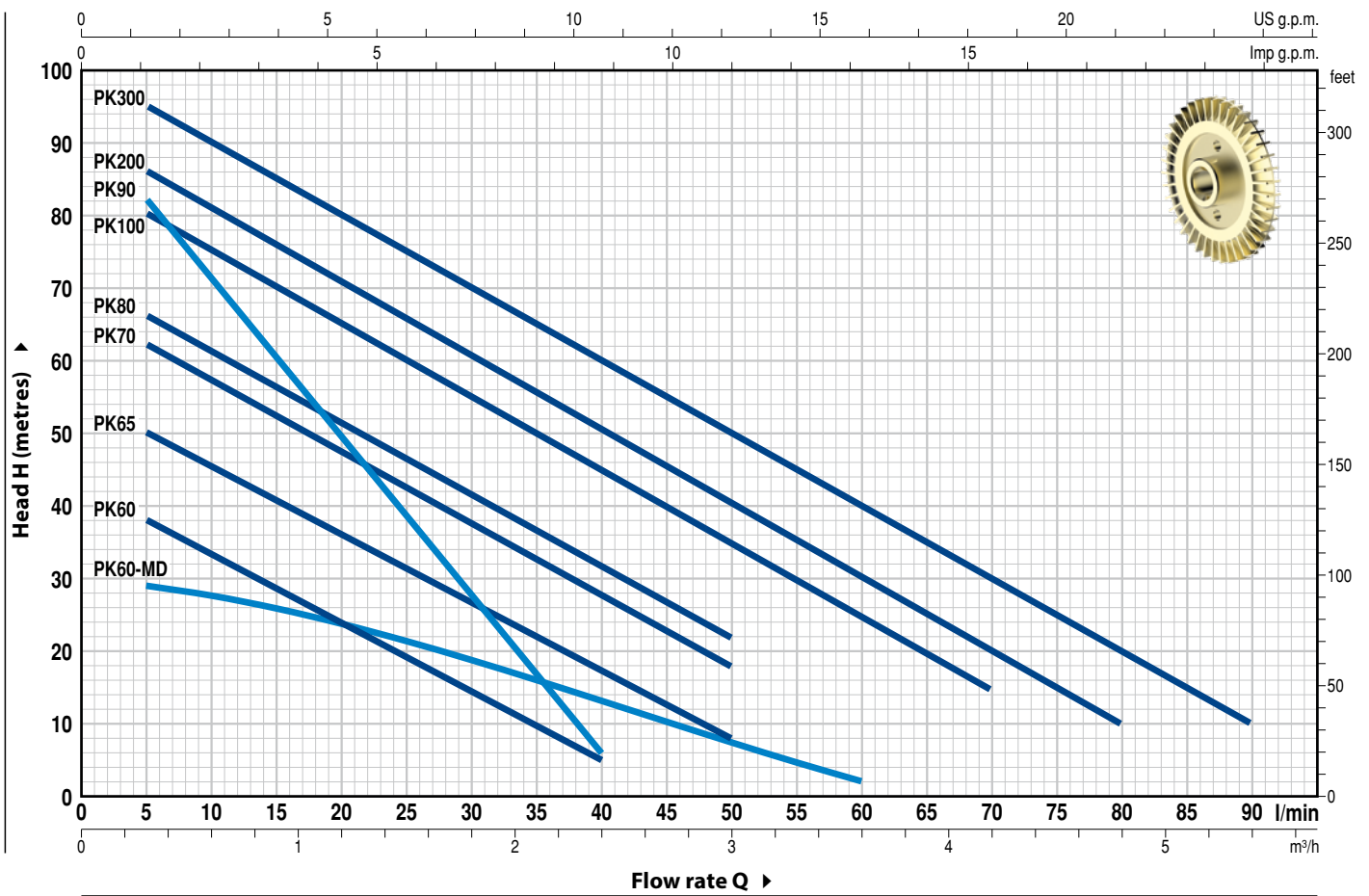



MODEL		POWER (P <sub>2</sub> )		▲	Q	Flow rate																		
Single-phase	Three-phase	kW	HP			m <sup>3</sup> /h	0	0.3	0.6	0.9	1.2	1.5	1.8	2.1	2.4	3.0	2.7	3.6	4.2	4.8	5.4			
					l/min	0	5	10	15	20	25	30	35	40	50	55	60	70	80	90				
PKm 60	PK 60	0.37	0.50	IE2	H metres	40	38	33.5	29	24	19.5	15	10	5										
PKm 60-MD	PK 60-MD	0.37	0.50			30	29	27.5	26	23.8	21.5	18.5	16	13.2	7.5	5	2							
PKm 65	PK 65	0.55	0.75			55	50	45.5	40.5	36	31	27	22	17	8									
PKm 70	PK 70	0.60	0.85			65	62	57	52	47	42	37	32	27	18									
PKm 80	PK 80	0.75	1	IE3		70	66	61	56	51	46	41	36.5	31	22									
PKm 90	PK 90	0.75	1			90	82	71	60	49	38	27	17	5										
PKm 100	PK 100	1.1	1.5			85	80	75	70	65	60	55	50	45	35	30	25	15						
PKm 200	PK 200	1.5	2			90	86	81	76	71	65.5	60	55	50	40	35	30	20	10					
PKm 300	PK 300	2.2	3			100	95	90	85	80	75	70	65	60	50	45	40	30	20	10				

Q = Flow rate H = Total manometric head HS = Suction height

Tolerance of characteristic curves in compliance with EN ISO 9906 Grade 3B.

▲ Three-phase motor efficiency class (IEC 60034-30-1)

## POS. COMPONENT CONSTRUCTION CHARACTERISTICS

1	<b>PUMP BODY</b>	Cast iron, with threaded ports in compliance with ISO 228/1 (PK 60, PK 60-MD with an Epoxy Electro Coating treatment)					
2	<b>MOTOR BRACKET</b>	Aluminium with brass insert (patented), reduces the risk of impeller seizure					
3	<b>IMPELLER</b>	Brass with peripheral radial vanes					
4	<b>MOTOR SHAFT</b>	Stainless steel AISI 431 (EN 10088-3 - 1.4104 for PK 60, PK 60-MD, PK 65)					
5	<b>MECHANICAL SEAL</b>	<i>Pump Model</i>	<i>Seal Model</i>	<i>Shaft Diameter</i>	<i>Stationary ring</i>	<i>Materials</i> <i>Rotational ring</i>	<i>Elastomer</i>
		PK 60-65-70-80 PK 60-MD	AR-12	Ø 12 mm	Ceramic	Graphite	NBR
		PK 90	ST1-12	Ø 12 mm	Silicon carbide	Graphite	NBR
		PK 100-200-300	FN-14	Ø 14 mm	Graphite	Ceramic	NBR
6	<b>BEARINGS</b>	<i>Pump Model</i>	<i>Model</i>				
		PK 60-65 PK 60-MD	6201 ZZ / 6201 ZZ				
		PK 70-80-90	6203 ZZ / 6203 ZZ				
		PK 100-200-300	6204 ZZ / 6204 ZZ				
7	<b>CAPACITOR</b>	EN 60252-1/A1					
8	<b>ELECTRIC MOTOR</b>	<p><b>PKm:</b> single-phase 220 V - 60 Hz with thermal overload protector incorporated into the winding.  <b>PK:</b> three-phase 220/380 V - 60 Hz or 220/440 V - 60 Hz.</p> <p>➔ <b>The three-phase pumps are fitted with high performance motors up to P<sub>2</sub>=0.55 kW in class IE2 and from P<sub>2</sub>=0.60 kW in class IE3 (IEC 60034-30-1)</b></p> <p>– Insulation: class F          – Protection: IP X4</p>					

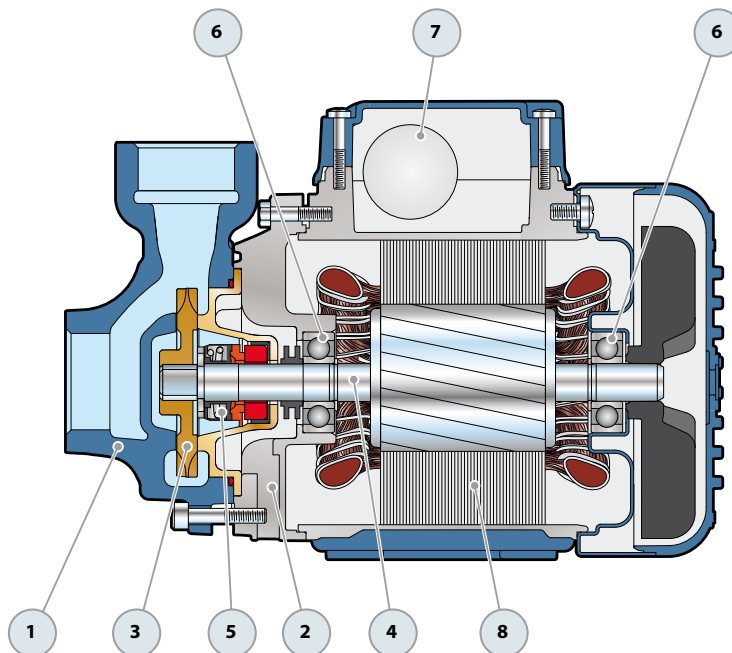

## DIMENSIONS AND WEIGHT

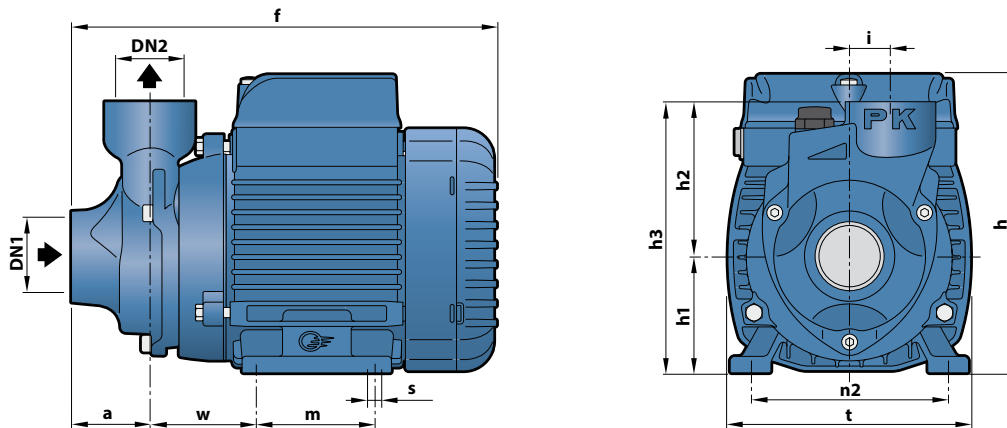

MODEL		PORTS		DIMENSIONS mm												kg			
Single-phase	Three-phase	DN1	DN2	a	f	h	h1	h2	h3	i	m	t	n2	w	s	1~	3~		
PKm 60°	PK 60°	1"	1"	38	208	145	56	75	131	20	55	118	94-100	53	7	5.2	5.2		
PKm 60°-MD	PK 60°-MD				237	153	63									80	120	100	7.0
PKm 65	PK 65			55	285	179 *	71	85	156		90	140	112	62		10.0	10.0		
PKm 70	PK 70			84	155			19	9.9							10.0			
PKm 80	PK 80	¾"	¾"	46	278			88	168	19	100	152	125	95	9	10.2	10.1		
PKm 90	PK 90	1"	1"	62	356	212	80	88	168	19	100	152	125	95	9	15.0	14.9		
PKm 100	PK 100				376													15.9	15.9
PKm 200	PK 200																		—
PKm 300	PK 300																		

(\*) h=199 mm for single-phase versions at 110 V

## ABSORPTION

MODEL	VOLTAGE		
Single-phase	220 V	110 V	127 V
PKm 60°	2.6 A	5.5 A	5.3 A
PKm 60°-MD	3.3 A	6.5 A	6.0 A
PKm 65	5.8 A	11.5 A	10.0 A
PKm 70	5.2 A	10.8 A	9.0 A
PKm 80	6.5 A	13.0 A	12.0 A
PKm 90	6.0 A	12.0 A	10.4 A
PKm 100	9.0 A	18.0 A	15.6 A
PKm 200	12.0 A	24.0 A	20.8 A
PKm 300	12.5 A	—	—

MODEL	TENSIONE			
Trifase	220 V	380 V	220 V	440 V
PK 60°	2.0 A	1.15 A	2.1 A	1.2 A
PK 60°-MD	2.4 A	1.4 A	2.5 A	1.4 A
PK 65	3.2 A	1.85 A	3.5 A	2.0 A
PK 70	3.8 A	2.2 A	3.8 A	2.2 A
PK 80	3.8 A	2.2 A	4.3 A	2.4 A
PK 90	4.2 A	2.4 A	4.2 A	2.4 A
PK 100	6.2 A	3.6 A	6.2 A	3.15 A
PK 200	9.2 A	5.3 A	7.0 A	4.2 A
PK 300	10.0 A	5.8 A	8.2 A	4.8 A

## CAPACITORS

MODEL	CAPACITANCE	
Single-phase	220 V	110 V or 127 V
PKm 60°	10 µF - 450 VL	25 µF - 250 VL
PKm 60°-MD	10 µF - 450 VL	25 µF - 250 VL
PKm 65	14 µF - 450 VL	60 µF - 300 VL
PKm 70	16 µF - 450 VL	60 µF - 300 VL
PKm 80	20 µF - 450 VL	60 µF - 300 VL
PKm 90	20 µF - 450 VL	60 µF - 250 VL
PKm 100	31.5 µF - 450 VL	80 µF - 250 VL
PKm 200	45 µF - 450 VL	-
PKm 300	50 µF - 450 VL	-

## PALLETIZATION

MODEL		GROUPAGE	CONTAINER
Single-phase	Three-phase	n. pumps	n. pumps
PKm 60°	PK 60°	240	330
PKm 60°-MD	PK 60°-MD	240	330
PKm 65	PK 65	189	243
PKm 70	PK 70	102	170
PKm 80	PK 80	102	170
PKm 90	PK 90	102	170
PKm 100	PK 100	72	96
PKm 200	PK 200	72	96
PKm 300	PK 300	72	96